

Elevator Car Top Maintenance Station

GMS375



TOTALLY CUSTOMIZABLE

Our strength is working together with the customer to create the best solution for its specific needs, creating a truly tailor-made product that qualitatively and functionally meets code and our partner requirements.



LIGHTING IMPROVEMENT

The **GMS375** incorporates two bright LED strip lights molded into the top of the inspection box.

This allows for additional focused yet flexible lighting on the car top in case of weak lighting conditions.



GIOVENZANA
INTERNATIONAL B.V.

INTEGRATED SOCKET

The **GMS375** also incorporates a UK RCD socket. Major international sockets can be fitted on request to adapt the inspection box to the global market.



Elevator Car Top Maintenance Station

GMS375

MAIN FEATURES

- Double high luminosity built-in led strips
- High impact
- Positive opening cam switch
- E-stop fail safe NC contact block
- 15° inclination base
- Self-monitored contact block as per LEIA/UK advice



PRODUCT COMPOSITION

	UK Socket RCD
	Pilot LED Light red and green, 24V
	Cam switch 0-1 normal-inspection switching 90°
	UP push button white, up arrow
	CONSENT push button blue, bidirectional arrow
	DOWN push button black, down arrow
	Emergency mushroom EN ISO 13850 ø60, push-pull with vision
	Door 1 Selector 1-0-2 3 positions, return to 0
	Light Selector 0-1 2 positions, 45° switching
	Alarm push button yellow, red ring
	Door 2 Selector 1-0-2 3 positions, return to 0

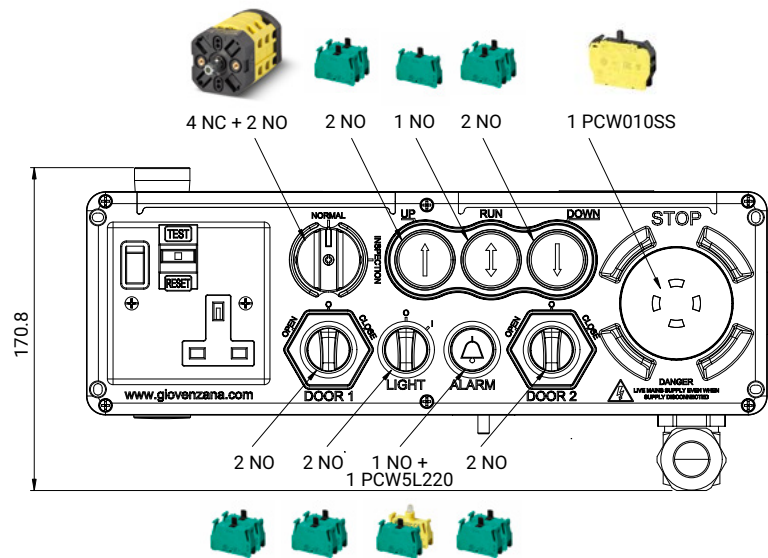

TECHNICAL DRAWINGS

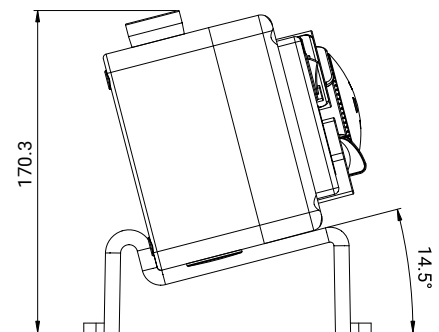
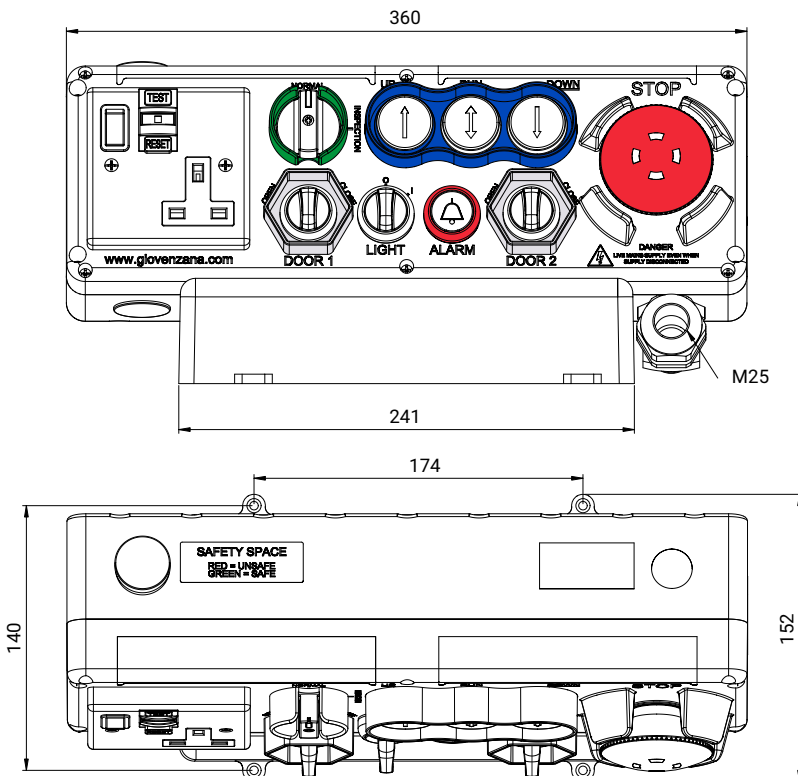

Further informations to
giovenzana@giovenzana.com