

**B FTN1R SERIES LIMIT SWITCHES WITH MANUAL RESET**
**DESCRIPTION**

The **FTN1R series** limit switches with manual reset, conform to EN 50047, have been developed to provide a range of options including a various choice of snap acting and slow acting and a wide range of actuator heads. The **FTN1R series** offers the option of rotating the head in 90° increments before installation to allow ease of mounting.

Giovenzana limit switches can be used in various applications in automation, lift and handling system fields. Operation of these limit switches is achieved by the sliding action of the guard or the moving object deflecting the plunger or lever. For safety applications it's important that upon actuation, the guard or other moving objects should not pass completely over the switch and allow the plunger or lever to return to its original position.

**TECHNICAL DATA - HOUSING**

Made of glass- reinforced polymer, self-extinguishing, shock-proof thermoplastic resin and with double insulation	
FTN1R Series one threaded conduit entry	Standard: M16
Protection degree	IP67 according to EN60529 with cable gland having equal or higher protection degree

**GENERAL DATA**

Positive opening operation	NC contact
Utilization category	AC15 A600
Minimum admissible current	5V, 5mA, DC
Insulation resistance	100MΩ min (DC 500V)
Contact resistance	25mΩ max (Initial)
Enclosure material	UL approved glass-filled polybutylene terephthalate
Operating temperature	Min -25°C (-18°F) / Max 80°C (+176°F)
Mechanical life expectancy	1x10 <sup>6</sup> cycles min
Electrically life expectancy	150.000 cycles min
Vibration resistance	IEC 68-2-6, 10-55Hz ± 1Hz, Excursion: 0.35mm, 1 octave/min
Conduit entry	Various
Fixing	2xM4

**ELECTRICAL DATA**

Rated thermal current (I <sub>th</sub> )	10A
Rated insulation voltage (U <sub>i</sub> )	600V AC
Rated impulse withstand voltage (U <sub>imp</sub> )	2500V AC
Pollution degree	3
Protection against electric shock	Class II (Double insulation)

**STANDARDS & APPROVALS**

Standards	EN60947-5-1, UL508, EN50047, EN1088
Approvals	cULus, EAC and CCC for all applicable directives

**QUALITY MARKS**

**MAIN FEATURES**

- Each model features a positive opening mechanism (NC contacts only) and equipped with a lockable head.
- Conforms to EN (TUV) standards corresponding to the CE marking.
- Positive opening operation of NC (Normally Closed) contacts conforming to IEC/EN 60947-5-1.
- Double insulation makes ground terminal unnecessary.
- Wide standard operating temperature range: -25°C to 80°C.
- Full range of actuator heads and levers suitable for safety applications.
- Sealing up to IP67.
- Wide switch variations (Snap action and slow action basic switches).

**ACCORDING TO STANDARDS**

**EN81.20** Safety contacts according to EN60947-5-1.  
**EN81.50** Protection degree higher than IP4x. Mechanical endurance higher than 1x10<sup>6</sup> cycles.

**INSTALLATION FOR SAFETY APPLICATIONS**

Use only switches marked with the symbol . Always connect the safety circuit to the **NC contact** (normally closed contacts: 11-12 / 21-22 / 31-32) as required by **EN ISO 14119 paragraph 5.4** and as stated in the standard **EN81.20 paragraph 5.11.2.1**.

**TAKE CARE!**

If not expressly indicated in this chapter, for the correct installation and utilization of all articles see the instructions given on pages 92-93.

**DATA TYPE APPROVED BY UL**
**Utilization categories:**

FTN1R SERIES	Q300	A600	1 NC/1 NO Slow Action 2 NC Slow Action
		B600	1 NC/1 NO Snap Action
		A300	2 NC/1 NO Slow Action (3 poles) 3 NC Slow Action (3 poles)

Data of the housing type 1.  
 For all contact blocks use 60 or 75°C copper (Cu) conductor and wire size No. 14 - 18 AWG.  
 Terminal tightening torque of 7.1 lb in (0.8 Nm).  
 In conformity with standard: UL508, CSA 22.2 No. 14 - 10.

Please contact our technical service for the list of approved products.

**PROTECTION CLASS**

**IP67** Designed to be used even in the most severe environmental situations, these devices pass the immersion test IP67 in conformity with EN 60529.

**DOUBLE INSULATION**

Materials of group II, according to IEC 536, are made with double insulation. This consists of doubling the insulation capability by means of an additional divider in order to eliminate any electrical shock risk and avoid the need for any additional protections.

**POSITIVE OPENING**

A limit switch complies to the specification when all the normally closed contact elements of the switch can be changed, with certainty, to the open position (no flexible link between the moving contacts and the operator of the switch, to which an actuating force is applied). Positive opening doesn't apply to NO contacts. Control switches with positive opening operation can be equipped with either slow-break or snap action contacts. In order to use different contacts on the same switch, it is necessary to electrically separate them; otherwise only one contact can be used. Every positive opening control switch must be marked on the external housing with the symbol on the left.

**OVERTURNING LEVERS**

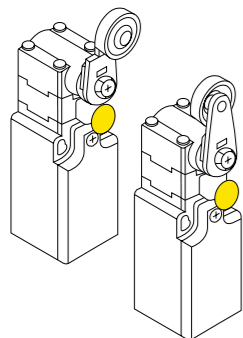

It's possible to fasten the lever on switches on straight or reverse side, maintaining the positive coupling. In this way it is possible to obtain two different work plans of the lever.

**ADJUSTABLE LEVERS**

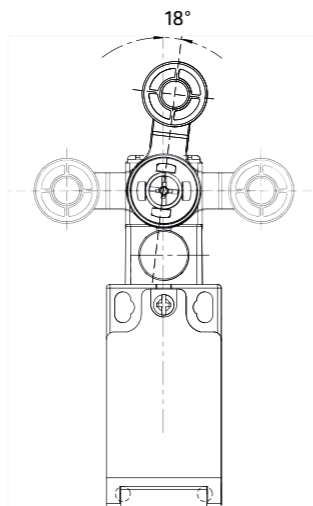

In switches with revolving lever it is possible to adjust the lever with 18° steps for the whole 360° range. The positive movement transmission is always guaranteed thanks to the particular geometrical coupling between the lever and the revolving shaft.

**ADAPTIVE PLATE**

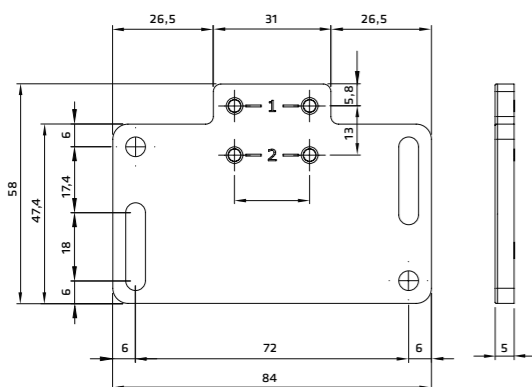

Fixing plate equipped with large slots for adjusting the operating point developed for backwards compatibility with old products. Each plate has a double pair of fixing holes.

The plate is sold in kit with **KIT-FTN** code.

- The **KIT-FTN** is inclusive of:
- 1 plate (code 12907009);
  - 2 self-tapping screws 4x28 mm;
  - 2 washers Ø4 mm.

**ROTATING RESET DEVICE**

The device can be rotated independently from the above actuator, making the product highly flexible in the positioning. The reset is obtained by pulling back the blue button, as prescribed by standards, to avoid that unwanted objects could reset it accidentally.

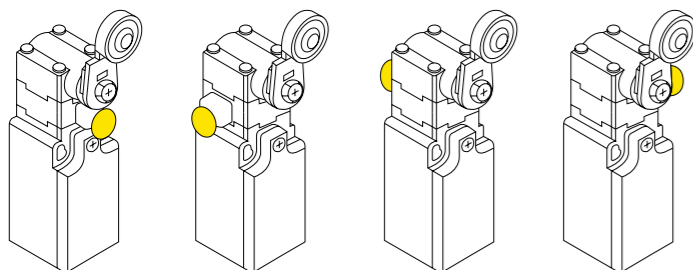

**ROTATING HEADS**

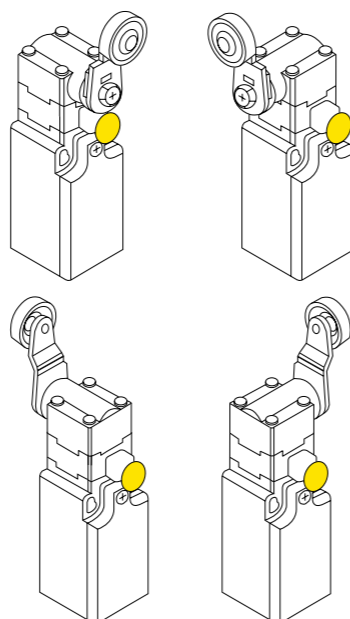

In all switches, it is possible to rotate the head in 90° steps.

**STRUCTURE DESCRIPTION**

**Metal Lever Setting**

Grooves which engage the lever every 18° are cut in the operation indicator disk to prevent the lever from slipping against the rotary shaft.

**Contact block**

Has a positive opening mechanism separating the contacts when the contacts are welded.

**Cover**

The cover, with a hinge on its lower part, can be opened by removing the screw of the cover, which ensures ease of maintenance and wiring.

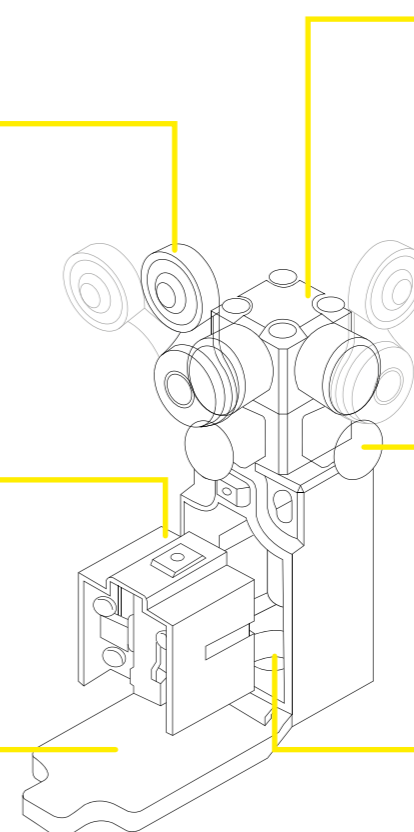

**Head**  
With roller lever models, the direction of the switch head can be adjusted to any of the four directions by loosening the roller lever switch screws at the four corners of the head.

**Reset Head**  
The direction of the reset head can be adjusted to any of the four directions.

**Conduit Entry**  
Standard: M16.  
On request: M20, 1/2NPT, PG11, PG13.5.

**PRODUCT SELECTION**

FTN	1R	31	X11	M
Series	Function	Head and actuators	Contact Types	Thread dimension of lead exit
	<b>1R</b> - With Reset Function	<b>31</b> - Push plunger type <b>32</b> - Roller lever type <b>33</b> - One-way roller arm lever type <b>34</b> - Roller plunger type <b>37</b> - Rod lever type <b>38</b> - Roller arm type <b>39</b> - Adjustable roller arm type (Long Arm) <b>40</b> - Adjustable roller arm type (Big Arm) <b>40R</b> - Two ways adjustable roller arm type <b>41</b> - Big roller arm type <b>43</b> - Mental roller arm type <b>44</b> - Adjustable roller arm type (Standard Arm)	<b>X11</b> - 1NC/1NO Slow Action <b>W02</b> - 2NC Slow Action <b>Z11</b> - 1NC/1NO Snap Action <b>W12</b> - 2NC/1NO Slow Action <b>W03</b> - 3NC Slow Action  Slow Action & Snap Action: Type "Zb"	Standard: <b>BLANK</b> - M16  On request: <b>M</b> - M20 <b>N</b> - 1/2NPT <b>G1</b> - PG11 <b>G3</b> - PG13.5 <b>C</b> - Connector

**CONTACT BLOCK FORM**

Contact Types	X11	W02	Z11	W12	W03
Contact Form	1NC/1NO Slow Action	2NC Slow Action	1NC/1NO Snap Action	2NC/1NO Slow Action	3NC Slow Action
Electrical Schemes					
Connector pin Arrangement				No Connector type	

M12 Connector pin arrangement - on request

**POSITIVE OPEN MECHANISM**

**1NC/NO Contact (Slow action)**

Only the NC contacts have a positive opening function. When metal deposition occurs, the contacts are separated from each other by pushing in the plunger.

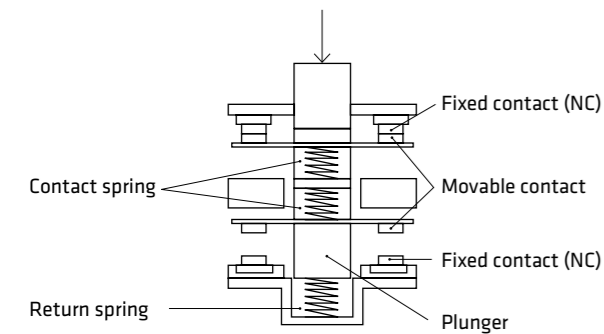

**2NC Contact (Slow action)**

Both NC contacts incorporate a positive opening function. When metal deposition occurs, the contacts are separated from each other by pushing in the plunger.

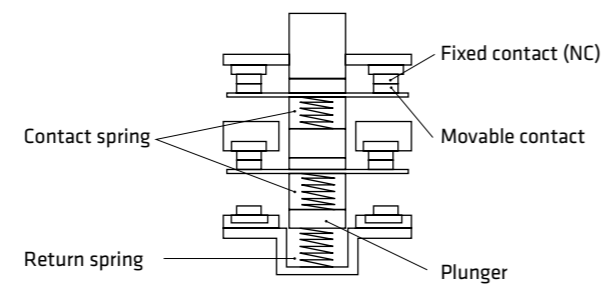

**SELECTION DIAGRAM**

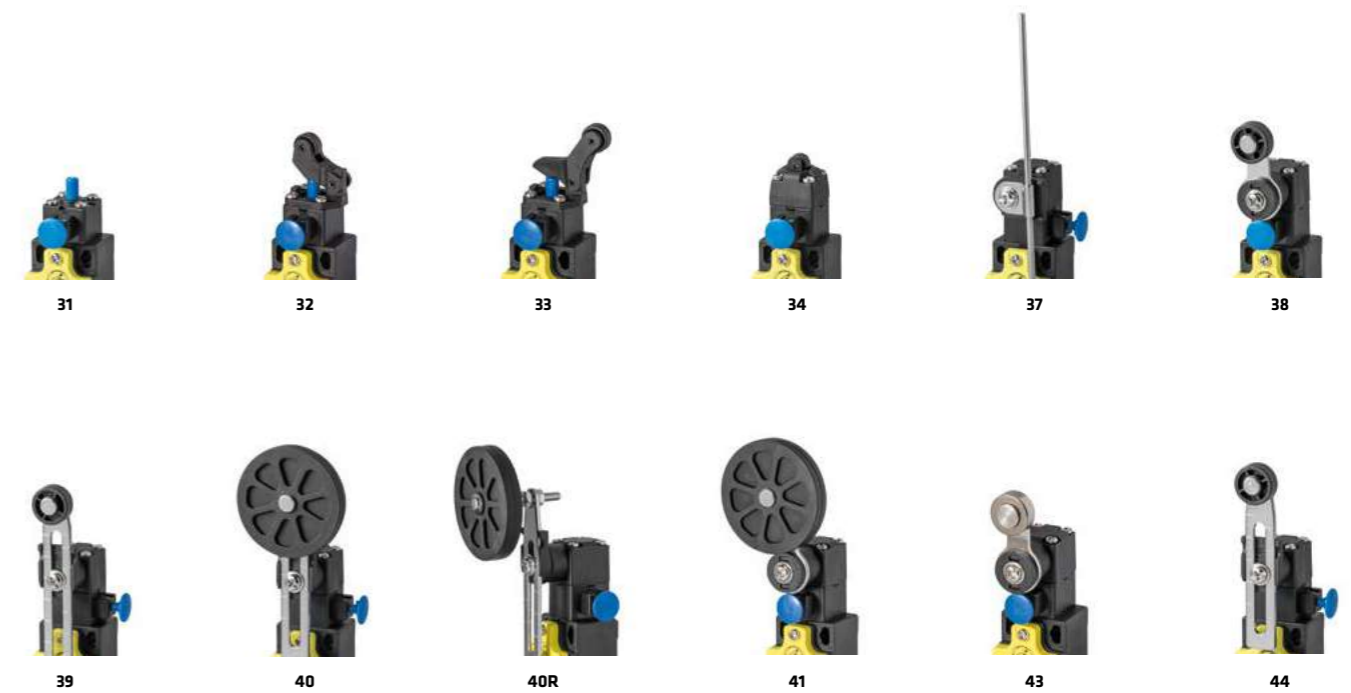

- X11** - 1NC/1NO Slow Action
- W02** - 2NC Slow Action
- Z11** - 1NC/1NO Snap Action
- W12** - 2NC/1NO Slow Action
- W03** - 3NC Slow Action

Accessory sell separately

- KIT-FTN** is inclusive of:
- 1 plate (code 12907009);
  - 2 self-tapping screws 4x28 mm;
  - 2 washers ø4 mm.

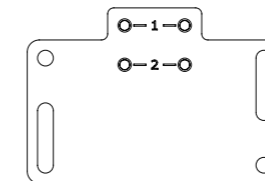

**Threaded conduit entry**

Standard:  
**BLANK** - M16

- On request:
- M** - M20
  - N** - 1/2NPT
  - G1** - PG11
  - G3** - PG13.5
  - C** - Connector

**Wiring**

Customized wirings are available on request, with connectors and cables in accordance with customers' specifications.

**ACTUATORS**

**CONTACT BLOCKS**

**FTN1R SERIES**

**ADAPTIVE PLATE**

**CONDUIT ENTRY**



**FTN1R31: Push plunger type**

FTN	1R	31	X11	M
Series	Function	Head and actuators	Contact Types	Thread dimension of lead exit
	1R - With Reset Function	31 - Push plunger type	<b>X11</b> - 1NC/1NO Slow Action <b>W02</b> - 2NC Slow Action <b>Z11</b> - 1NC/1NO Snap Action <b>W12</b> - 2NC/1NO Slow Action <b>W03</b> - 3NC Slow Action  Slow Action & Snap Action: Type "Zb"	Standard: <b>BLANK</b> - M16 On request: <b>M</b> - M20 <b>N</b> - 1/2NPT <b>G1</b> - PG11 <b>G3</b> - PG13.5 <b>C</b> - Connector

**OPERATION DIAGRAMS**

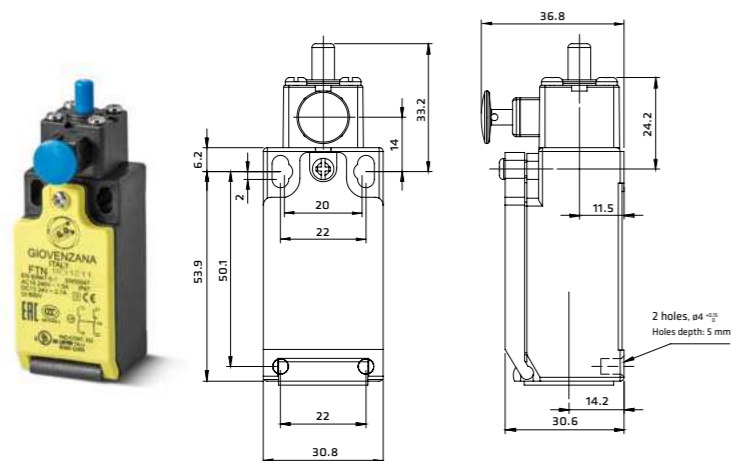
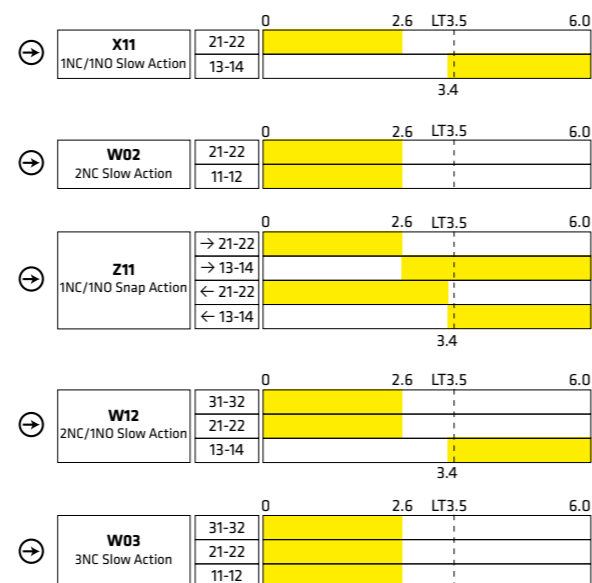

**FTN1R33: One-way roller arm lever type**

FTN	1R	33	X11	M
Series	Function	Head and actuators	Contact Types	Thread dimension of lead exit
	1R - With Reset Function	33 - One-way roller arm lever type	<b>X11</b> - 1NC/1NO Slow Action <b>W02</b> - 2NC Slow Action <b>Z11</b> - 1NC/1NO Snap Action <b>W12</b> - 2NC/1NO Slow Action <b>W03</b> - 3NC Slow Action  Slow Action & Snap Action: Type "Zb"	Standard: <b>BLANK</b> - M16 On request: <b>M</b> - M20 <b>N</b> - 1/2NPT <b>G1</b> - PG11 <b>G3</b> - PG13.5 <b>C</b> - Connector

**OPERATION DIAGRAMS**

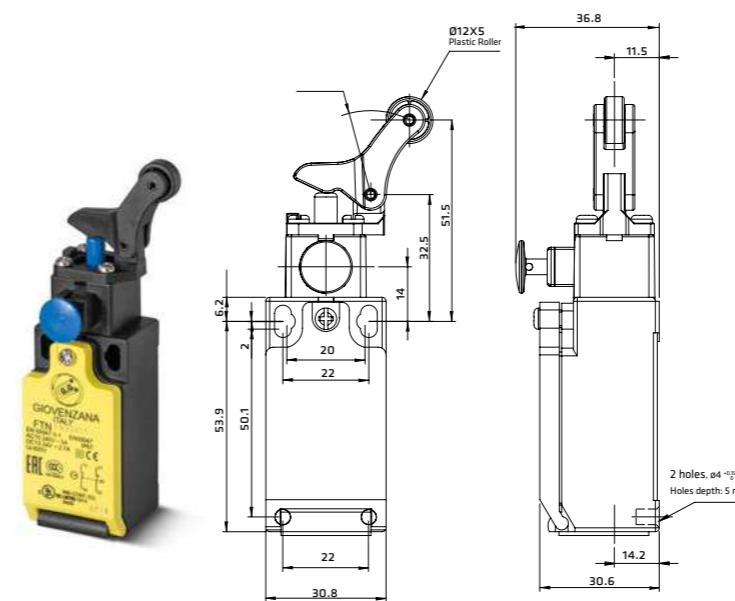
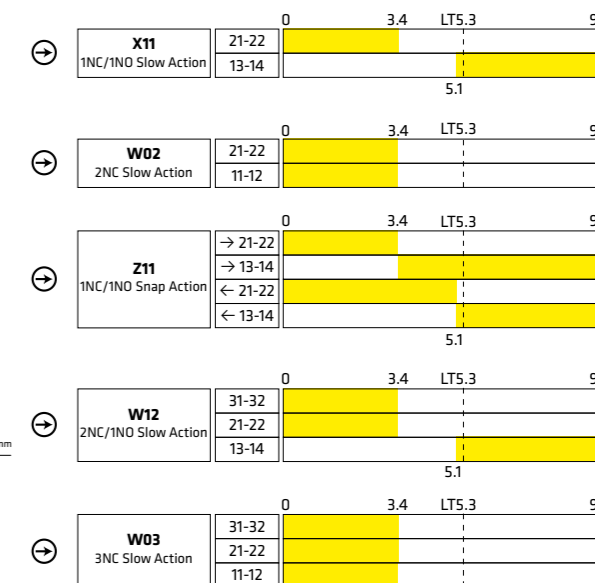

**FTN1R32: Roller lever type**

FTN	1R	32	X11	M
Series	Function	Head and actuators	Contact Types	Thread dimension of lead exit
	1R - With Reset Function	32 - Roller lever type	<b>X11</b> - 1NC/1NO Slow Action <b>W02</b> - 2NC Slow Action <b>Z11</b> - 1NC/1NO Snap Action <b>W12</b> - 2NC/1NO Slow Action <b>W03</b> - 3NC Slow Action  Slow Action & Snap Action: Type "Zb"	Standard: <b>BLANK</b> - M16 On request: <b>M</b> - M20 <b>N</b> - 1/2NPT <b>G1</b> - PG11 <b>G3</b> - PG13.5 <b>C</b> - Connector

**OPERATION DIAGRAMS**

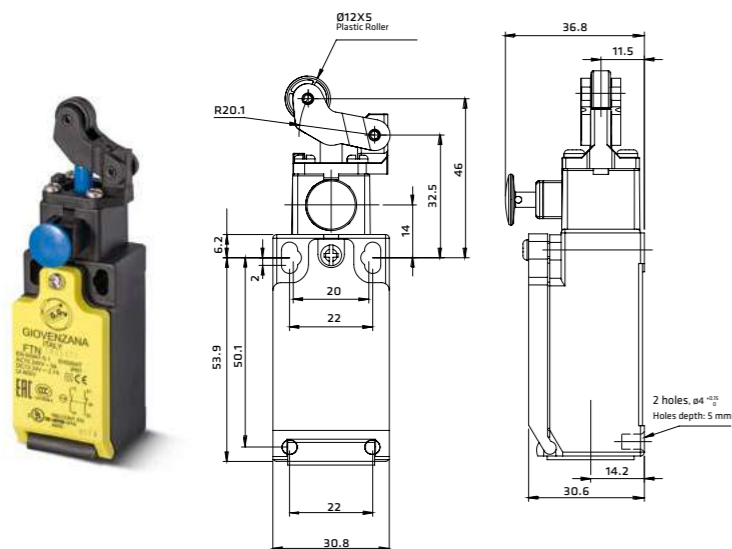
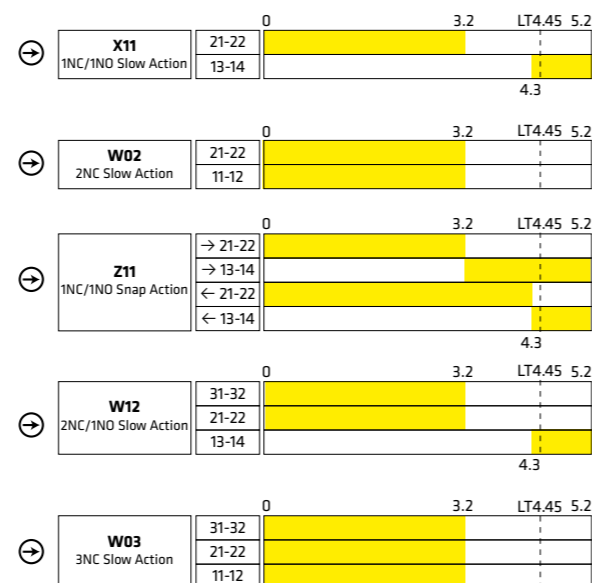

**FTN1R34: Roller plunger type**

FTN	1R	34	X11	M
Series	Function	Head and actuators	Contact Types	Thread dimension of lead exit
	1R - With Reset Function	34 - Roller plunger type	<b>X11</b> - 1NC/1NO Slow Action <b>W02</b> - 2NC Slow Action <b>Z11</b> - 1NC/1NO Snap Action <b>W12</b> - 2NC/1NO Slow Action <b>W03</b> - 3NC Slow Action  Slow Action & Snap Action: Type "Zb"	Standard: <b>BLANK</b> - M16 On request: <b>M</b> - M20 <b>N</b> - 1/2NPT <b>G1</b> - PG11 <b>G3</b> - PG13.5 <b>C</b> - Connector

**OPERATION DIAGRAMS**

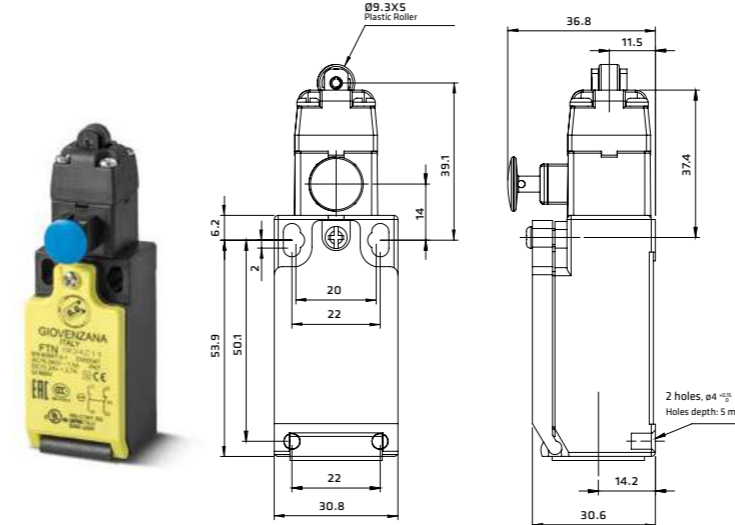
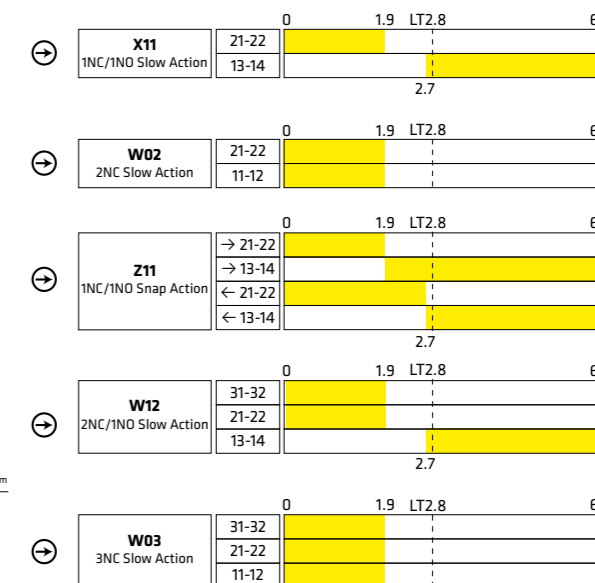



**FTN1R37: Rod lever type**

FTN	1R	37	X11	M
Series	Function	Head and actuators	Contact Types	Thread dimension of lead exit
	1R - With Reset Function	37 - Rod lever type	<b>X11</b> - 1NC/1NO Slow Action <b>W02</b> - 2NC Slow Action <b>Z11</b> - 1NC/1NO Snap Action <b>W12</b> - 2NC/1NO Slow Action <b>W03</b> - 3NC Slow Action  Slow Action & Snap Action: Type "Zb"	Standard: <b>BLANK</b> - M16 On request: <b>M</b> - M20 <b>N</b> - 1/2NPT <b>G1</b> - PG11 <b>G3</b> - PG13.5 <b>C</b> - Connector

**OPERATION DIAGRAMS**

X11 1NC/1NO Slow Action	21-22	80° LT43.5° 28°.32° 0 28°.32° LT43.5° 80°
	13-14	38°.42° 38°.42°
W02 2NC Slow Action	21-22	80° LT43.5° 28°.32° 0 28°.32° LT43.5° 80°
	11-12	
Z11 1NC/1NO Snap Action	→ 21-22	80° LT43.5° 25°.28° 0 25°.28° LT43.5° 80°
	→ 13-14	
	← 21-22	
	← 13-14	11°.14° 11°.14°
W12 2NC/1NO Slow Action	31-32	80° LT43.5° 28°.32° 0 28°.32° LT43.5° 80°
	21-22	
	13-14	38°.42° 3.4 38°.42°
W03 3NC Slow Action	31-32	80° LT43.5° 28°.32° 0 28°.32° LT43.5° 80°
	21-22	
	11-12	

**FTN1R39: Adjustable roller arm type (Long Arm)**

FTN	1R	39	X11	M
Series	Function	Head and actuators	Contact Types	Thread dimension of lead exit
	1R - With Reset Function	39 - Adjustable roller arm type (Long Arm)	<b>X11</b> - 1NC/1NO Slow Action <b>W02</b> - 2NC Slow Action <b>Z11</b> - 1NC/1NO Snap Action <b>W12</b> - 2NC/1NO Slow Action <b>W03</b> - 3NC Slow Action  Slow Action & Snap Action: Type "Zb"	Standard: <b>BLANK</b> - M16 On request: <b>M</b> - M20 <b>N</b> - 1/2NPT <b>G1</b> - PG11 <b>G3</b> - PG13.5 <b>C</b> - Connector

**OPERATION DIAGRAMS**

X11 1NC/1NO Slow Action	21-22	80° LT43.5° 28°.32° 0 28°.32° LT43.5° 80°
	13-14	38°.42° 38°.42°
W02 2NC Slow Action	21-22	80° LT43.5° 28°.32° 0 28°.32° LT43.5° 80°
	11-12	
Z11 1NC/1NO Snap Action	→ 21-22	80° LT43.5° 25°.28° 0 25°.28° LT43.5° 80°
	→ 13-14	
	← 21-22	
	← 13-14	11°.14° 11°.14°
W12 2NC/1NO Slow Action	31-32	80° LT43.5° 28°.32° 0 28°.32° LT43.5° 80°
	21-22	
	13-14	38°.42° 3.4 38°.42°
W03 3NC Slow Action	31-32	80° LT43.5° 28°.32° 0 28°.32° LT43.5° 80°
	21-22	
	11-12	

**FTN1R38: Roller arm type**

FTN	1R	38	X11	M
Series	Function	Head and actuators	Contact Types	Thread dimension of lead exit
	1R - With Reset Function	38 - Roller arm type	<b>X11</b> - 1NC/1NO Slow Action <b>W02</b> - 2NC Slow Action <b>Z11</b> - 1NC/1NO Snap Action <b>W12</b> - 2NC/1NO Slow Action <b>W03</b> - 3NC Slow Action  Slow Action & Snap Action: Type "Zb"	Standard: <b>BLANK</b> - M16 On request: <b>M</b> - M20 <b>N</b> - 1/2NPT <b>G1</b> - PG11 <b>G3</b> - PG13.5 <b>C</b> - Connector

**OPERATION DIAGRAMS**

X11 1NC/1NO Slow Action	21-22	80° LT43.5° 28°.32° 0 28°.32° LT43.5° 80°
	13-14	38°.42° 38°.42°
W02 2NC Slow Action	21-22	80° LT43.5° 28°.32° 0 28°.32° LT43.5° 80°
	11-12	
Z11 1NC/1NO Snap Action	→ 21-22	80° LT43.5° 25°.28° 0 25°.28° LT43.5° 80°
	→ 13-14	
	← 21-22	
	← 13-14	11°.14° 11°.14°
W12 2NC/1NO Slow Action	31-32	80° LT43.5° 28°.32° 0 28°.32° LT43.5° 80°
	21-22	
	13-14	38°.42° 3.4 38°.42°
W03 3NC Slow Action	31-32	80° LT43.5° 28°.32° 0 28°.32° LT43.5° 80°
	21-22	
	11-12	

**FTN1R40: Adjustable roller arm type (Big Arm)**

FTN	1R	40	X11	M
Series	Function	Head and actuators	Contact Types	Thread dimension of lead exit
	1R - With Reset Function	40 - Adjustable roller arm type (Big Arm)	<b>X11</b> - 1NC/1NO Slow Action <b>W02</b> - 2NC Slow Action <b>Z11</b> - 1NC/1NO Snap Action <b>W12</b> - 2NC/1NO Slow Action <b>W03</b> - 3NC Slow Action  Slow Action & Snap Action: Type "Zb"	Standard: <b>BLANK</b> - M16 On request: <b>M</b> - M20 <b>N</b> - 1/2NPT <b>G1</b> - PG11 <b>G3</b> - PG13.5 <b>C</b> - Connector

**OPERATION DIAGRAMS**

X11 1NC/1NO Slow Action	21-22	80° LT43.5° 28°.32° 0 28°.32° LT43.5° 80°
	13-14	38°.42° 38°.42°
W02 2NC Slow Action	21-22	80° LT43.5° 28°.32° 0 28°.32° LT43.5° 80°
	11-12	
Z11 1NC/1NO Snap Action	→ 21-22	80° LT43.5° 25°.28° 0 25°.28° LT43.5° 80°
	→ 13-14	
	← 21-22	
	← 13-14	11°.14° 11°.14°
W12 2NC/1NO Slow Action	31-32	80° LT43.5° 28°.32° 0 28°.32° LT43.5° 80°
	21-22	
	13-14	38°.42° 3.4 38°.42°
W03 3NC Slow Action	31-32	80° LT43.5° 28°.32° 0 28°.32° LT43.5° 80°
	21-22	
	11-12	

**FTN1R40R: Two ways adjustable roller arm type**

FTN	1R	40R	X11	M
Series	Function	Head and actuators	Contact Types	Thread dimension of lead exit
	1R - With Reset Function	40R - Two ways adjustable roller arm type	<b>X11</b> - 1NC/1NO Slow Action <b>W02</b> - 2NC Slow Action <b>Z11</b> - 1NC/1NO Snap Action <b>W12</b> - 2NC/1NO Slow Action <b>W03</b> - 3NC Slow Action  Slow Action & Snap Action: Type "Zb"	Standard: <b>BLANK</b> - M16 On request: <b>M</b> - M20 <b>N</b> - 1/2NPT <b>G1</b> - PG11 <b>G3</b> - PG13.5 <b>C</b> - Connector

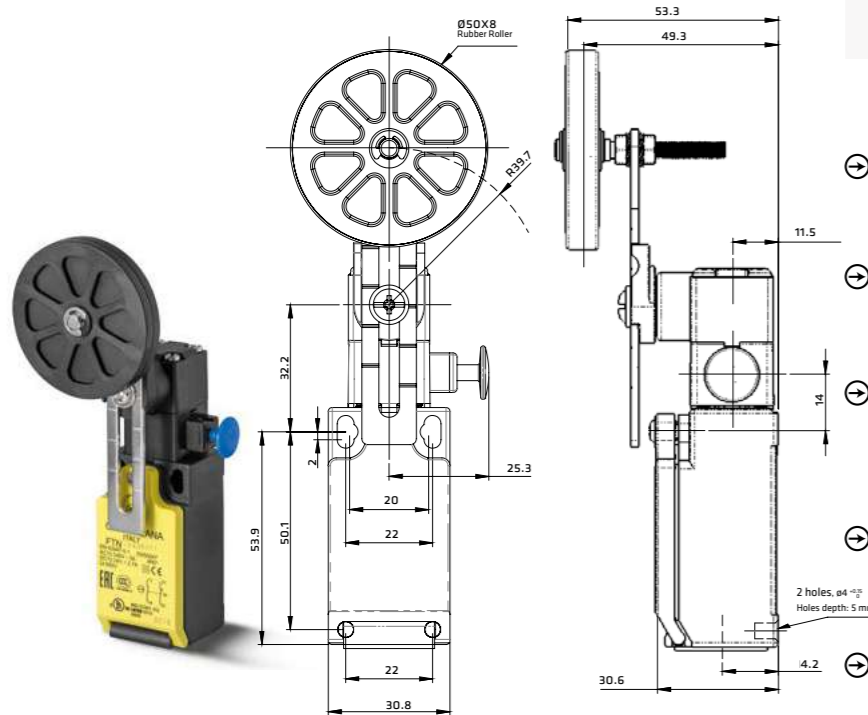

**OPERATION DIAGRAMS**

X11 1NC/1NO Slow Action	21-22	80° LT43.5° 28°.32° 0 28°.32° LT43.5° 80°
	13-14	38°.42° 38°.42°
W02 2NC Slow Action	21-22	80° LT43.5° 28°.32° 0 28°.32° LT43.5° 80°
	11-12	
Z11 1NC/1NO Snap Action	→ 21-22	80° LT43.5° 25°.28° 0 25°.28° LT43.5° 80°
	→ 13-14	
	← 21-22	
	← 13-14	11°.14° 11°.14°
W12 2NC/1NO Slow Action	31-32	80° LT43.5° 28°.32° 0 28°.32° LT43.5° 80°
	21-22	
	13-14	38°.42° 3.4 38°.42°
W03 3NC Slow Action	31-32	80° LT43.5° 28°.32° 0 28°.32° LT43.5° 80°
	21-22	
	11-12	

**FTN1R41: Big roller arm type**

FTN	1R	41	X11	M
Series	Function	Head and actuators	Contact Types	Thread dimension of lead exit
	1R - With Reset Function	41 - Big roller arm type	<b>X11</b> - 1NC/1NO Slow Action <b>W02</b> - 2NC Slow Action <b>Z11</b> - 1NC/1NO Snap Action <b>W12</b> - 2NC/1NO Slow Action <b>W03</b> - 3NC Slow Action  Slow Action & Snap Action: Type "Zb"	Standard: <b>BLANK</b> - M16 On request: <b>M</b> - M20 <b>N</b> - 1/2NPT <b>G1</b> - PG11 <b>G3</b> - PG13.5 <b>C</b> - Connector

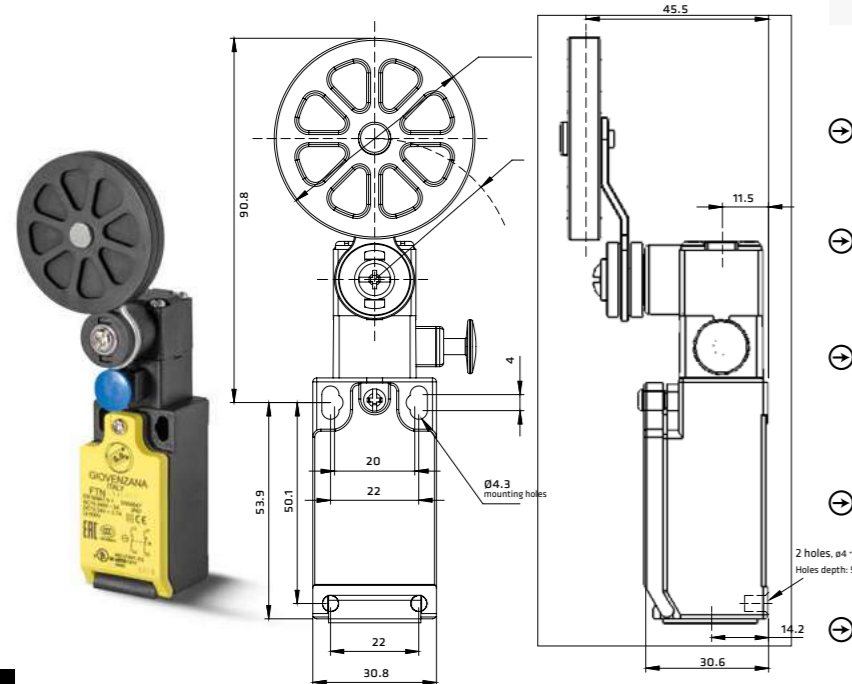

**OPERATION DIAGRAMS**

X11 1NC/1NO Slow Action	21-22	80° LT43.5° 28°.32° 0 28°.32° LT43.5° 80°
	13-14	38°.42° 38°.42°
W02 2NC Slow Action	21-22	80° LT43.5° 28°.32° 0 28°.32° LT43.5° 80°
	11-12	
Z11 1NC/1NO Snap Action	→ 21-22	80° LT43.5° 25°.28° 0 25°.28° LT43.5° 80°
	→ 13-14	
	← 21-22	
	← 13-14	11°.14° 11°.14°
W12 2NC/1NO Slow Action	31-32	80° LT43.5° 28°.32° 0 28°.32° LT43.5° 80°
	21-22	
	13-14	38°.42° 3.4 38°.42°
W03 3NC Slow Action	31-32	80° LT43.5° 28°.32° 0 28°.32° LT43.5° 80°
	21-22	
	11-12	

**FTN1R43: Mental roller arm type**

FTN	1R	43	X11	M
Series	Function	Head and actuators	Contact Types	Thread dimension of lead exit
	1R - With Reset Function	43 - Mental roller arm type	<b>X11</b> - 1NC/1NO Slow Action <b>W02</b> - 2NC Slow Action <b>Z11</b> - 1NC/1NO Snap Action <b>W12</b> - 2NC/1NO Slow Action <b>W03</b> - 3NC Slow Action  Slow Action & Snap Action: Type "Zb"	Standard: <b>BLANK</b> - M16 On request: <b>M</b> - M20 <b>N</b> - 1/2NPT <b>G1</b> - PG11 <b>G3</b> - PG13.5 <b>C</b> - Connector

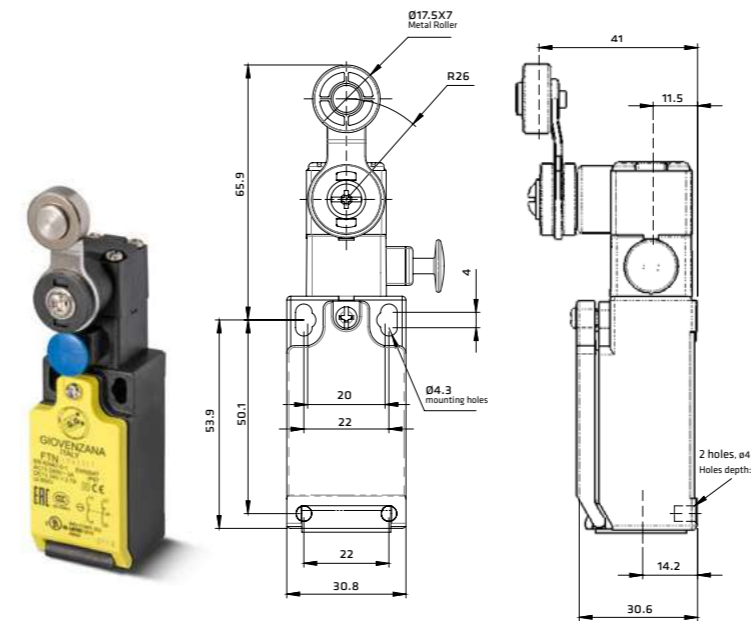

**OPERATION DIAGRAMS**

X11 1NC/1NO Slow Action	21-22	80° LT43.5° 28°.32° 0 28°.32° LT43.5° 80°
	13-14	38°.42° 38°.42°
W02 2NC Slow Action	21-22	80° LT43.5° 28°.32° 0 28°.32° LT43.5° 80°
	11-12	
Z11 1NC/1NO Snap Action	→ 21-22	80° LT43.5° 25°.28° 0 25°.28° LT43.5° 80°
	→ 13-14	
	← 21-22	
	← 13-14	11°.14° 11°.14°
W12 2NC/1NO Slow Action	31-32	80° LT43.5° 28°.32° 0 28°.32° LT43.5° 80°
	21-22	
	13-14	38°.42° 3.4 38°.42°
W03 3NC Slow Action	31-32	80° LT43.5° 28°.32° 0 28°.32° LT43.5° 80°
	21-22	
	11-12	

**FTN1R44: Adjustable roller arm type (Standard Arm)**



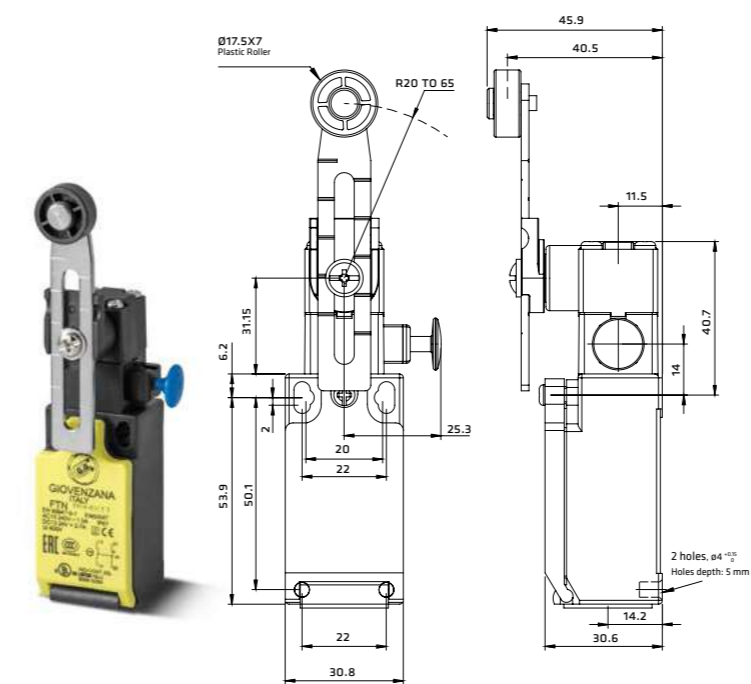

FTN	1R	44	X11	M
Series	Function	Head and actuators	Contact Types	Thread dimension of lead exit
	1R - With Reset Function	44 - Adjustable roller arm type (Standard Arm)	<b>X11</b> - 1NC/1NO Slow Action <b>W02</b> - 2NC Slow Action <b>Z11</b> - 1NC/1NO Snap Action <b>W12</b> - 2NC/1NO Slow Action <b>W03</b> - 3NC Slow Action  Slow Action & Snap Action: Type "Zb"	Standard: <b>BLANK</b> - M16 On request: <b>M</b> - M20 <b>N</b> - 1/2NPT <b>G1</b> - PG11 <b>G3</b> - PG13.5 <b>C</b> - Connector





**OPERATION DIAGRAMS**

X11 1NC/1NO Slow Action	21-22	80° LT43.5° 28°.32° 0 28°.32° LT43.5° 80°
	13-14	38°.42° 38°.42°
W02 2NC Slow Action	21-22	80° LT43.5° 28°.32° 0 28°.32° LT43.5° 80°
	11-12	
Z11 1NC/1NO Snap Action	→ 21-22	80° LT43.5° 25°.28° 0 25°.28° LT43.5° 80°
	→ 13-14	
	← 21-22	
	← 13-14	11°.14° 11°.14°
W12 2NC/1NO Slow Action	31-32	80° LT43.5° 28°.32° 0 28°.32° LT43.5° 80°
	21-22	
	13-14	38°.42° 3.4 38°.42°
W03 3NC Slow Action	31-32	80° LT43.5° 28°.32° 0 28°.32° LT43.5° 80°
	21-22	
	11-12	

**OPERATING FORCE FTN1R SERIES**

TYPE	CONTACT BLOCK		OPERATING TRAVEL		OPERATING FORCE OF	POSITIVE OPENING		TOTAL TRAVEL
			PT	PT2nd		Travel	Force	
	X11	1 NC/1 NO Slow Action	2.2 mm	3.0 mm	7.26 N	3.2 mm	19.0 N	6.0 mm
	W02	2 NC Slow Action	2.2 mm	-	7.42 N			
	Z11	1 NC/1 NO Snap Action	1.9 mm	-	6.71 N			
	W12	2 NC/1 NO Slow Action	2.2 mm	3.0 mm	7.26 N			
	W03	3 NC Slow Action	2.2 mm	-	7.42 N			
	X11	1 NC/1 NO Slow Action	3.0 mm	4.5 mm	5.21 N	5.7 mm	19.0 N	5.2 mm
	W02	2 NC Slow Action	3.0 mm	-	5.26 N			
	Z11	1 NC/1 NO Snap Action	2.9 mm	-	4.74 N			
	W12	2 NC/1 NO Slow Action	3.0 mm	4.5 mm	5.21 N			
	W03	3 NC Slow Action	3.0 mm	-	5.26 N			
	X11	1 NC/1 NO Slow Action	4.0 mm	6.0 mm	6.37 N	4.6 mm	19.0 N	9.8 mm
	W02	2 NC Slow Action	4.0 mm	-	6.98 N			
	Z11	1 NC/1 NO Snap Action	3.6 mm	-	5.76 N			
	W12	2 NC/1 NO Slow Action	4.0 mm	6.0 mm	6.37 N			
	W03	3 NC Slow Action	4.0 mm	-	6.98 N			
	X11	1 NC/1 NO Slow Action	2.2 mm	3.0 mm	7.26 N	3.2 mm	19.0 N	6.0 mm
	W02	2 NC Slow Action	2.2 mm	-	7.42 N			
	Z11	1 NC/1 NO Snap Action	1.9 mm	-	6.71 N			
	W12	2 NC/1 NO Slow Action	2.2 mm	3.0 mm	7.26 N			
	W03	3 NC Slow Action	2.2 mm	-	7.42 N			
	X11	1 NC/1 NO Slow Action	30°	41°	1.8 N	45°	19.0 N	80°
	W02	2 NC Slow Action	30°	-	1.8 N			
	Z11	1 NC/1 NO Snap Action	28°	-	1.9 N			
	W12	2 NC/1 NO Slow Action	30°	41°	1.8 N			
	W03	3 NC Slow Action	30°	-	1.8 N			
	X11	1 NC/1 NO Slow Action	30°	41°	6.5 N	45°	19.0 N	80°
	W02	2 NC Slow Action	30°	-	6.5 N			
	Z11	1 NC/1 NO Snap Action	28°	-	5.3 N			
	W12	2 NC/1 NO Slow Action	30°	41°	6.5 N			
	W03	3 NC Slow Action	30°	-	6.5 N			
	X11	1 NC/1 NO Slow Action	30°	41°	1.8 N	45°	19.0 N	80°
	W02	2 NC Slow Action	30°	-	1.8 N			
	Z11	1 NC/1 NO Snap Action	28°	-	1.9 N			
	W12	2 NC/1 NO Slow Action	30°	41°	1.8 N			
	W03	3 NC Slow Action	30°	-	1.8 N			
	X11	1 NC/1 NO Slow Action	30°	41°	5.2 N	45°	19.0 N	80°
	W02	2 NC Slow Action	30°	-	5.2 N			
	Z11	1 NC/1 NO Snap Action	28°	-	4.5 N			
	W12	2 NC/1 NO Slow Action	30°	41°	5.2 N			
	W03	3 NC Slow Action	30°	-	5.2 N			
	X11	1 NC/1 NO Slow Action	30°	41°	6.5 N	45°	19.0 N	80°
	W02	2 NC Slow Action	30°	-	6.5 N			
	Z11	1 NC/1 NO Snap Action	35°	-	5.3 N			
	W12	2 NC/1 NO Slow Action	30°	41°	6.5 N			
	W03	3 NC Slow Action	30°	-	6.5 N			

**OPERATING FORCE FTN1R SERIES**

TYPE	CONTACT BLOCK		OPERATING TRAVEL		OPERATING FORCE OF	POSITIVE OPENING		TOTAL TRAVEL
			PT	PT2nd		Travel	Force	
	X11	1 NC/1 NO Slow Action	30°	41°	6.5 N	45°	19.0 N	80°
	W02	2 NC Slow Action	30°	-	6.5 N			
	Z11	1 NC/1 NO Snap Action	35°	-	5.3 N			
	W12	2 NC/1 NO Slow Action	30°	41°	6.5 N			
	W03	3 NC Slow Action	30°	-	6.5 N			
	X11	1 NC/1 NO Slow Action	30°	41°	6.5 N	45°	19.0 N	80°
	W02	2 NC Slow Action	30°	-	6.5 N			
	Z11	1 NC/1 NO Snap Action	35°	-	5.3 N			
	W12	2 NC/1 NO Slow Action	30°	41°	6.5 N			
	W03	3 NC Slow Action	30°	-	6.5 N			
	X11	1 NC/1 NO Slow Action	30°	41°	6.5 N	45°	19.0 N	80°
	W02	2 NC Slow Action	30°	-	6.5 N			
	Z11	1 NC/1 NO Snap Action	28°	-	5.3 N			
	W12	2 NC/1 NO Slow Action	30°	41°	6.5 N			
	W03	3 NC Slow Action	30°	-	6.5 N			